



**WENDLAND**

R O O F S O L U T I O N S



## Livinroof Technical Guide

v1 | December 2019

## DEAR TRADE PARTNER OR CONSERVATORY BUYER,

Based on the Classic glazed roof technology it's familiarity to surveyors and fitters is one of its main strengths. Livinroof is a cost effective, simple to fit pre-packaged solid roof kit that is aimed at the replacement of tired conservatory roofs

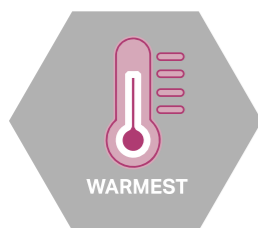

### WARMEST

#### Unrivalled thermal performance

- A true warm roof system with no cold bridging.
- U-Value as low as 0.16.
- **Thermally insulated** internal pelmet as standard.
- **Thermally broken** rafters.



### LIGHTEST

#### The lightest solid roof on the market

- Weighs only 31kg/m<sup>2</sup> **lighter than any other solid roof.**
- Designed by conservatory specialists, to **replace existing conservatory roofs.**
- **Lightweight panels** are cut to size and easy to manoeuvre.



### VERSATILE

#### The most configurable solid roofing system available

- Ideal for solid replacement solution for low pitched lean-tos with **pitches from 5 to 40.9°.**
- Advanced software to instantly validate structural requirements of **any complex designs.**
- **Shaped glazing** inserted anywhere in the roof at no extra cost.



### FIRE TESTED

#### Independently and fully fire tested

- The complete, assembled Livinroof structure was **fire tested in 2017** by Warringtonfire.
- Livinroof is **fire rated as B-roof** according to EN 13501-5: 2016.
- Livinroof aluminium panel is **fire rated as AA** according to BS476-3:2004.



### SAFEST

#### The only solid roof engineered to postcode

- NASA satellite data used to **precision engineer every roof** for Wind AND snow loads.
- Wind tested to withstand to hurricane winds up to 130mph.
- Independently fire tested BS476 part 3.
- **Super strong** eaves beam, ridge, valley and jack rafter.



### BRIGHTEST

#### More glazing options than any other solid roof

- **Shaped glazing** for a bespoke and stunning internal design.
- **Highly configurable** glazed panels for natural light where needed.
- Performance glass easily integrated **at no extra cost.**



Livinroof is a cost effective, simple to fit pre-packaged solid roof kit that is aimed at the replacement of tired conservatory roofs.

Based on Classic glazed roof technology it's familiarity to surveyors and fitters is one of its main strengths.

Livinroof substantially overcomes – for the consumer – the twin issues of the conservatory being too hot in summer and too cold in winter. Moreover, it creates a beautiful vaulted plastered ceiling inside and with a stepped detail at the eaves using the insulated internal pelmet system, the perfect place for cables and spotlights.

For those consumers who still want an element of light through their new solid roof, the clever configurable technology allows the fitment of multiple glass panels – this can be a major consideration for the adjacent room that the consumer needs to consider.

Please read this document carefully to ensure you are familiar with Livinroof specification.

**For assistance with Livinroof design/specification please contact the Technical Support team on 01200 452318 or customerservice@wendland.uk.com**

## Using this System Overview & Design Guide

Reading this guide early in the design/quotation process may save time later and more importantly the consumer may not have the budget to proceed. Careful pre-sales survey/checks can ease the process – undertaking a pilot hole dig alongside the base for example and inviting the Local Authority building inspector (or other Approved Building Control Inspectors like Jhai). You may be able to charge the consumer a 'deposit' for this inspection, redeemed if the project goes ahead.

## CONTENTS

Livinroof System Overview	4
Key features and benefits	5-6
Principles of replacing glazed roofs with solid roofs	7
Similarities (and differences) to Classic glazed roof	8
- Specification items	8
- System overview	9-12
- Panel sizes/centres	13
- Glazed panel layout guidance	14
Assessing the existing conservatory	15-18
Order Form	19-20
Appendix 1 Resin Anchors	21
Appendix 2 Cavity tray assessment	21
Appendix 3 Tie bars	22
Appendix 4 Super duty eaves beam	23
Appendix 5 Spanning Performance - System Elements	24

## This is what you receive with Livinroof

- Roof in RAL7016 'matt effect'
- 90mm High Performance PU board insulation, cut to all shapes.
- 25mm High Performance PU board insulation as secondary layer.
- Black Marley Classic gutter.
- High performance sealed units

(Not supplied - resin anchors and plasterboard)

### IMPORTANT - NOTE 1

The installer is responsible for ensuring that where Livinroof is supported by means such as timber frame walls, the structure provides enough lateral support and resistance to wind uplift. Further guidance can be obtained through this guide's technical documentation. Wendland cannot be responsible for the structural adequacy of any existing building work used as part of an overall conversion. While assistance is provided, ultimate responsibility to secure Building Regulations lies with the retail installer. **IF IN DOUBT ABOUT STRUCTURAL COMPLIANCE, PLEASE CONSULT LABC, Jhai OR A STRUCTURAL ENGINEER**

### IMPORTANT - NOTE 2

This guide is intended to provide indicative information and to help you understand the design principles and applicable loadings. U-Design is the final arbiter on price and specification decisions.

### IMPORTANT - NOTE 3

The Livinroof components have been designed and manufactured to meet the specification of each individual job. Any significant on site modifications particularly relating to the repositioning of any structural members will invalidate the product's warranty and compromise the structures integrity. If adjustments are required due to site conditions please consult Wendland.



## OVERVIEW

### Product definition

Livinroof is purpose designed for the replacement of tired glazed conservatory roofs. Externally it uses roof bars painted in RAL7016 urban grey and glazed with insulated panels. Internally it uses two separate insulation layers (provided). At the eaves, the internal pelmet engineered steelwork ladder system is used - all internal roof surfaces are then plaster boarded (see below for specification, not supplied) before being plaster skimmed.

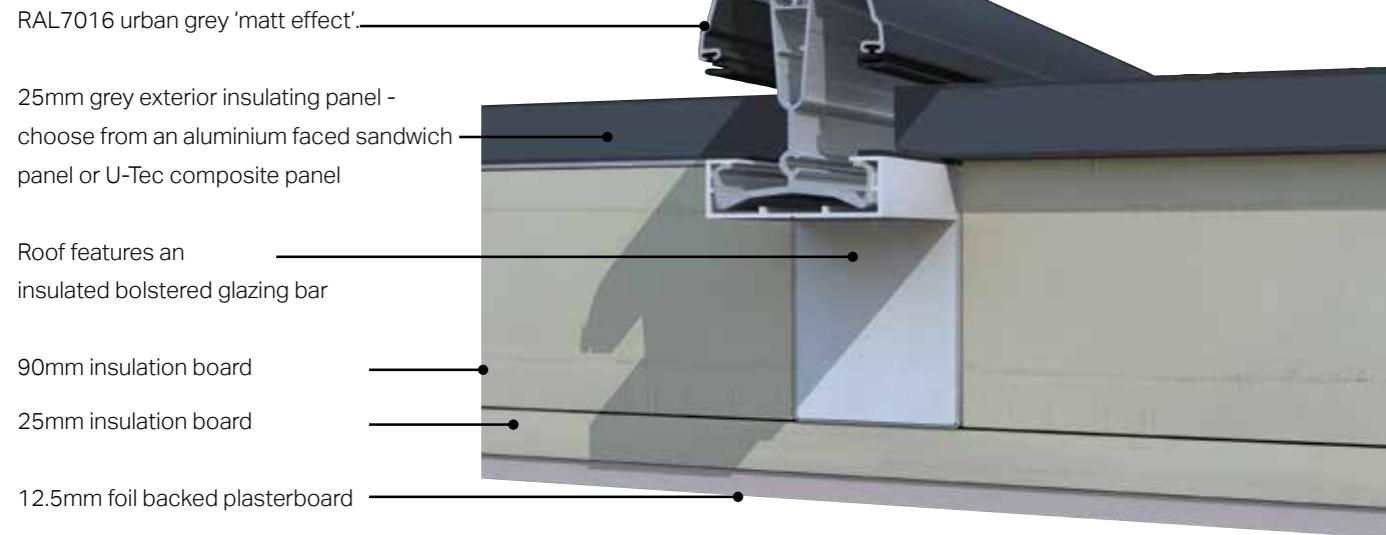

### Key performance criteria

- A pre-packaged solid roof that can be configured to suit virtually any existing conservatory roof that is to be converted - variable pitches and differential pitches no problem.
- Livinroof is based on BBA certified Classic roof chassis, the first glazed roof with this important third party accreditation and the only solid roof replacement product based on a BBA certified platform.
- LABC Assured Details demonstrate compliance with Building Regulations.
- Jhai, Approved Building Control Inspectors. In England and Wales they can undertake Building Regulation inspections for a uniform approach across all localities. See separate brochure for Jhai information and application form.
- U-Value of 0.16 W/m<sup>2</sup>K – warm roof, vaulted ceiling.
- Features internal pelmet system set at 300mm projection (ability to vary projection too), better finishing detail at eaves and perfect for cables and lights.
- Glass panels can be integrated to maintain light into any adjacent room – no additional cost to swap solid panels for high performance glazing.
- Everything is pre-fabricated in our highly efficient factory to ensure rapid one day fit on site.
- On a 4m x 4m Georgian, the system weight is 31kg/M<sup>2</sup> including plasterboard (12kg/m<sup>2</sup> polycarbonate roof and 30kg for a glass roof).

### Building Regulations requirement

Wendland takes a responsible position and recognises that this glazed to solid conversion activity means the conservatory is no longer exempt. Checks should be made on the structural integrity of the frames and base before conversion takes place. Wendland recommends various techniques to check/upgrade existing frames/bases. Livinroof can also be used in new extensions.

### U-Design

U-Design is a piece of design and configuration software that exclusively specifies Livinroof. As well as visualising and pricing, upon entry of the customers postcode it checks the wind and snow loads at the exact location to ensure Livinroof comply's with Building Regulations.

**It is strongly recommended that the Livinroof installation guide and the Building Regulations process brochure are read at the same time as this System Technical Guide.**

## 01

**The Livinroof roof has a 0.16 U-Value which is 15 times more thermally efficient than a 16mm polycarbonate or older glass roof without solar control.**

The room will be cooler in the summer and warmer in the winter.

Heating costs will be reduced.

The room can be used 365 days of the year.

It's worth offering the homeowner the options of new frames, since modern glazing specifications will complement the thermal performance of the roof making the room more comfortable & cheaper to heat.

## 02

**Jhai provides Building Regulations completion certificates (England & Wales)**

Building Regulation compliance is required for solid roof conversions and new build extensions. Jhai partnership provides peace of mind regarding the performance of the roof and to ensure that there are no problems with compliance when the homeowner decides to sell their home.

Jhai provides a low cost consistent way of complying with Building Regulations across England and Wales in a practical, pragmatic approach.

## 03

**Livinroof is supplied in RAL7016 Urban Grey as standard.**

This has the appearance of a rolled lead roof with a conservatory feel.

When installed it looks very similar to the appearance of a subtle blue glass roof, reflecting the sky.

It is less likely to show the dirt whereas other colours may.

## TOP TEN MAJOR FEATURES & BENEFITS



## 04

**Livinroof has a system weight of 31kg/m<sup>2</sup> (including plasterboard) – much lighter than other replacement roofs.**

Whilst around the same weight as a glass roof this often enables the original window frames to be used providing a saving to the homeowner if required.

The difference in loading on the foundations is negligible. Provided there is no sign of settlement in the base there is no need to excavate a pilot hole to reveal the foundations. Please consult Jhai if you are in any doubt.

## 05

**Livinroof is offered with black Marley Classic gutter as standard with the option to have the powder coated gutter cover.**

The PVCu gutter option enables homeowners with a tight budget to take advantage of the benefits of Livinroof.

Gutter cover provides the wow factor! The easy to install system can be specified in grey to match the roof, the same colour as the frames, or in a bespoke colour that complements or contrasts with the frames. This enables the homeowner to be creative and make their mark on their new home improvement project.

# 06

**Glass panels can be integrated virtually anywhere into the design of the Livinroof without additional cost to the home owner. This includes shaped panels.**

This adds visual appeal to the design of the extension.

The homeowner has an individual design that is their own.

Take advantage of the sweep of the sun over the extension by choosing which panels to glaze and which to leave solid. Which brings light into rooms in the house that would otherwise be darker with a solid roof.

Watch TV in the Livinroof extension without suffering problems with glare whilst having the benefit of natural light.

Unlike other solid roofs, brings more light into the room adjacent, crucial if replacing an old glazed roof.



# 07

**An internal pelmet is part of the design, with a horizontal soffit inside the extension. The standard projection of the internal pelmet is 300mm but it can be varied, (with a max up to 1200mm).**

You can put downlights of your choice within the internal pelmet around the perimeter of the extension, providing attractive mood lighting.

You could fit speakers to internal pelmet with hidden cables led through to your amplifier, this should be considered for first-fix cabling.

# 08

**Livinroof has a vaulted ceiling and a plastered finish.**

The vaulted ceiling provides a light spacious feel to the extension.

The plasterboard finish makes the extension feel as though it is part of the house.

# 09



**Livinroof is based on the Classic BBA certified platform and carries a 10 year guarantee.**

The roof has a proven pedigree and will provide comfort and peace of mind for the homeowner for many years to come.

The roof can be configured like any other conservatory roof, providing the retailer with confidence that they can replicate existing designs on refurbishment projects.

The system enables variable pitches to be specified, useful when height restriction apply, including the ability to produce lean-to designs as low as 5 degrees.

Fitters are familiar with the system, so a speedy swop from old to new with no risk of damaging existing floors/finishes.

# 10

**Create a simple plastered 'flat top' at the apex to suspend lights from.**

This allows the homeowner to specify downlights or pendant lights of their choice to be fixed under the ridge for main or mood lighting.

Adds further visual identity to the extension roof internally.

## PRINCIPLES OF REPLACING CONSERVATORY ROOFS

Wendland is a responsible manufacturer and takes its market position seriously. There is some confusion out in the market amongst those who already have or are about to tackle their first glazed to solid conversion.

Wendland has consulted with LABC and the leading Approved Building Control Inspectors Jhai and our advice and notes are based on their positions – both organisations believe that Building Regulations DO apply when glazed to solid roof conversion work is executed.

As a responsible member of the Glass and Glazing Federation, our position is one that ALL responsible retailers MUST follow these guidelines.

Changing the roof on a previously exempt conservatory from glazing to solid panels means that you have changed the status of the structure. The new roof is seen as an improvement and MUST comply with parts of the Building Regulations (this assumes the doors separating the house and conservatory are retained). There is a caveat – the replacement roof should not make the condition of the existing structure worse – this relates to the ability of the existing side frames and foundations to carry the additional loads imposed by the solid roof.

Providing adequate support can be reviewed for three main areas;

1. Window frames
2. Mullions/corner posts
3. Foundations

Pages 13-18 give detailed guidance on how to assess these areas and ensure compliance.

The minimum fire performance rating required by Building Regulations for roofs is AC based on the following classifications.

### FIRST LETTER

#### PENETRATION CLASSIFICATIONS

- A** Specimens not penetrated within 1 hour
- B** Specimens penetrated in not less than half hour
- C** Specimens penetrated in less than half hour
- D** Specimens penetrated in the preliminary flame test

### SECOND LETTER

#### SPREAD OF FLAME CLASSIFICATIONS

- A** Specimens with no spread of flame
- B** Specimens with not more than 533mm spread of flame
- C** Specimens with more than 533mm spread of flame
- D** Specimens which continue to burn for 5 mins after the withdrawal of the test flame or spread more than 381mm in the preliminary test.

**The assembled Livinroof has been independently fire tested by Exova Warrington Fire and has been rated:**

**AA when 25mm aluminium faced sandwich panel installed.**

**AB when 25mm U-Tec composite panel installed.**





## CLASSIC ROOF CHASSIS – SIMILARITIES AND DIFFERENCES

Livinroof is based on the highly configurable BBA certified Classic roof chassis which gives the roof tremendous ability to accommodate varying pitches, sizes and shapes. It will nearly always be the case that if there is an existing conservatory roof to be replaced, Livinroof will be able to substitute a roof that is extremely similar.

There are a number of elements / parts that are new or that exist as options today and that will be mandatory on Livinroof. At the heart of Livinroof is an insulated steel bolster glazing bar which greatly increases the strength /span performance and which provides a sound fixing for the 12.5mm plasterboard. Linked to the point above is the reduction in bar centres to 600mm. This ensures that the plasterboard is correctly supported and eliminates movement deflection (leading to micro cracking in the plasterwork). The roof now features the eaves beam mouldings at host wall positions (resin anchor fixed) and the compression plate at the ridge end. In some situations a bolster is added at the ridge and additional cleats specified at the eaves beam corners).



At the heart of Livinroof is a series of insulated bolstered glazing bars - boosts spanning and reduces deflection.

Where the eaves beam sits against the host masonry wall, it has a structural moulding attached to the eaves beam. This has three fixing positions cast into it to allow attachment into masonry - choose the hole that directly lines up with solid masonry and attach using one resin anchor suitable for substrate / loads (not supplied, see p21, appendix 1).

The ridge hanger/compression plate is attached to the host wall using two anchor bolts (not supplied).

All roofs feature struts at the ridge, covered by an insulated ridge board. See p22, appendix 3 for further guidance on struts and various tie bar situations/options



## ADDITIONAL STRUCTURAL SPECIFICATION ITEMS (SOFTWARE SPECIFIES)

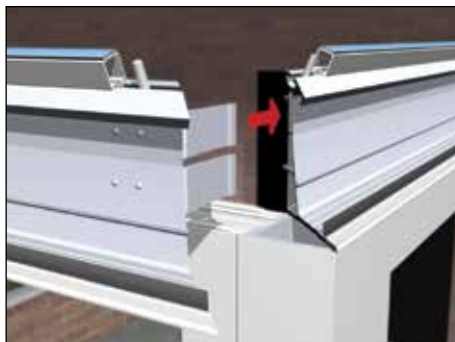

Each eaves corner (90°, 135° and 150°) is supplied pre-fitted with an additional standard cleat. Additional cleat (2 in total) on 90°, 135° and 150° corners.

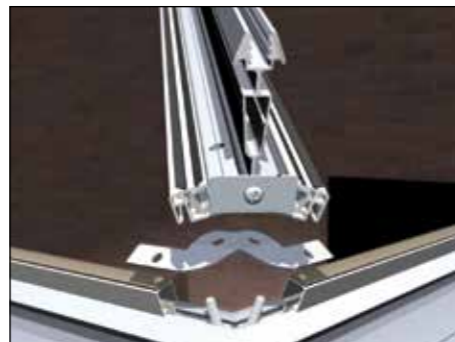

On Georgian / 90° corners, a butterfly cleat is laid over two captivated roofing bolts. Note: A butterfly cleat is not required on 3 or 5 facet fronts unless the eaves beam joins a box gutter at the facet joint.

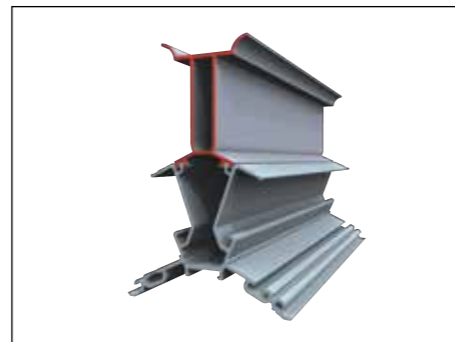

An aluminium bolster beam is factory stitched and extends along the entire length of the ridge and acts as one with the existing aluminium ridge body to virtually eliminate deflection.

## SYSTEM OVERVIEW

Transom Bar - solid/glass - on fascia



Transom Bar - solid/glass - below fascia



## SYSTEM OVERVIEW

Box Gutter - solid/glass - below fascia



Box Gutter - solid/solid - below fascia



## SYSTEM OVERVIEW

Valley - solid/solid



Hip - solid/solid





## SYSTEM OVERVIEW

Gable - glass

**PLEASE DO NOT ORDER / MANUFACTURE GABLE FRAMES BEFORE DISCUSSION WITH WENDLAND TECHNICAL SUPPORT ON 01200 452318.**

Gable frame sizes on Livinroof roofs are different to regular glass roofs.



Gable - solid

**PLEASE DO NOT ORDER / MANUFACTURE GABLE FRAMES BEFORE DISCUSSION WITH WENDLAND TECHNICAL SUPPORT ON 01200 452318.**

Gable frame sizes on Livinroof roofs are different to regular glass roofs.



## PANEL SIZES / CENTRES

Unlike traditional glazed roofs where bar centres typically are 750 - 900mm apart, on Livinroof they are at a maximum standard of 600mm centres - this is because plasterboard is a material that needs further support than a traditional glass roof (to prevent deflection and thereby micro cracking in the plasterwork). See additional notes below.

Wendland's design/manufacturing software specifies bar spacings and panel sizes.

### Bar layout on 4 x 4m Georgian Roof

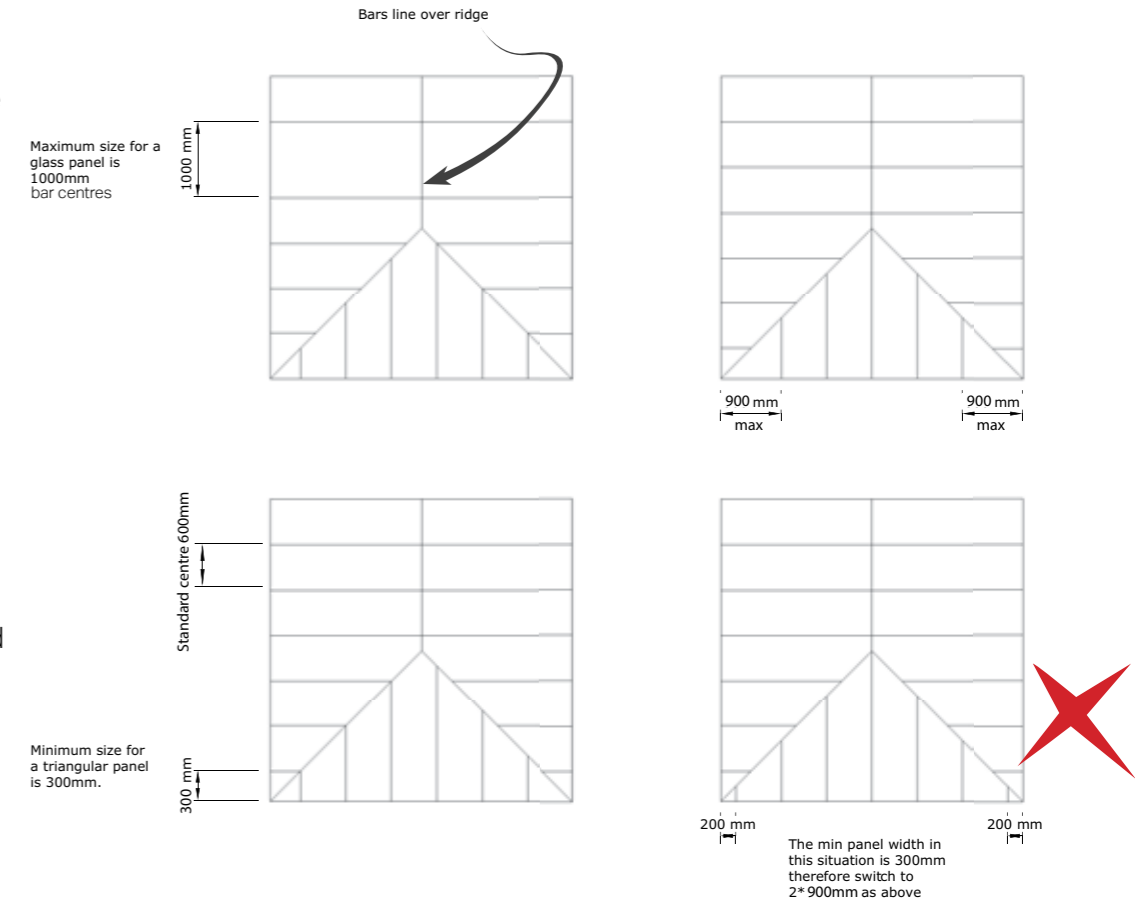

### Bar layout on 4 x 4m Victorian & Lean-to Roof

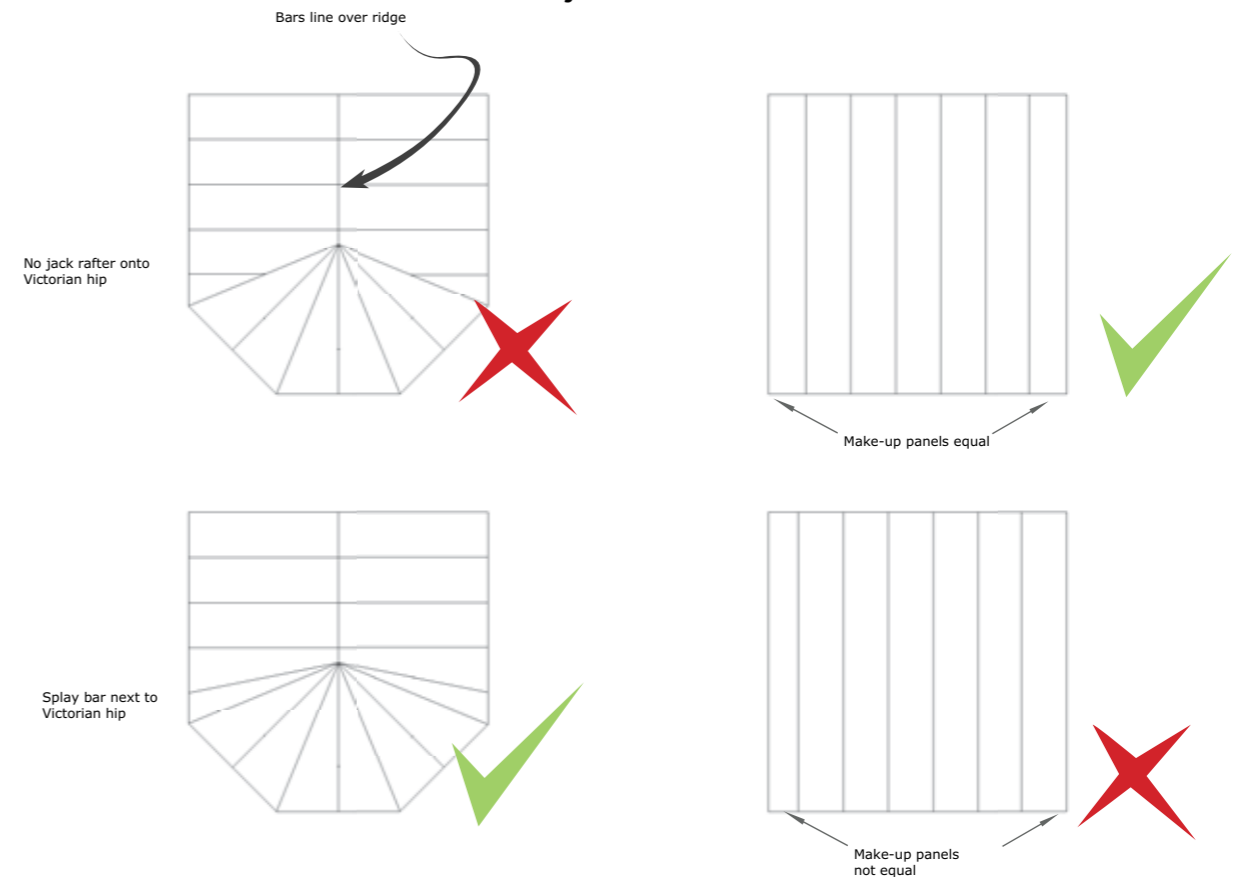

## GLAZED PANEL LAYOUT GUIDANCE

Glass panels can be inserted in virtually any position within the roof. If Livinroof is used as part of a new extension, only 25% of the floor area can be represented as glazed elements (vertical wall frames and roof combined).

For example: a 4mx4m floor plan = 4sqm of glazing with windows at 1.6 U-Value (energy rating C) and doors at 1.8 U-Value. Deploying units with improved U-Values may increase the percentage of allowable glazing. Obtaining SAP calculations or achieving 'trade offs' via Jhai will confirm this.

Bars line over ridge

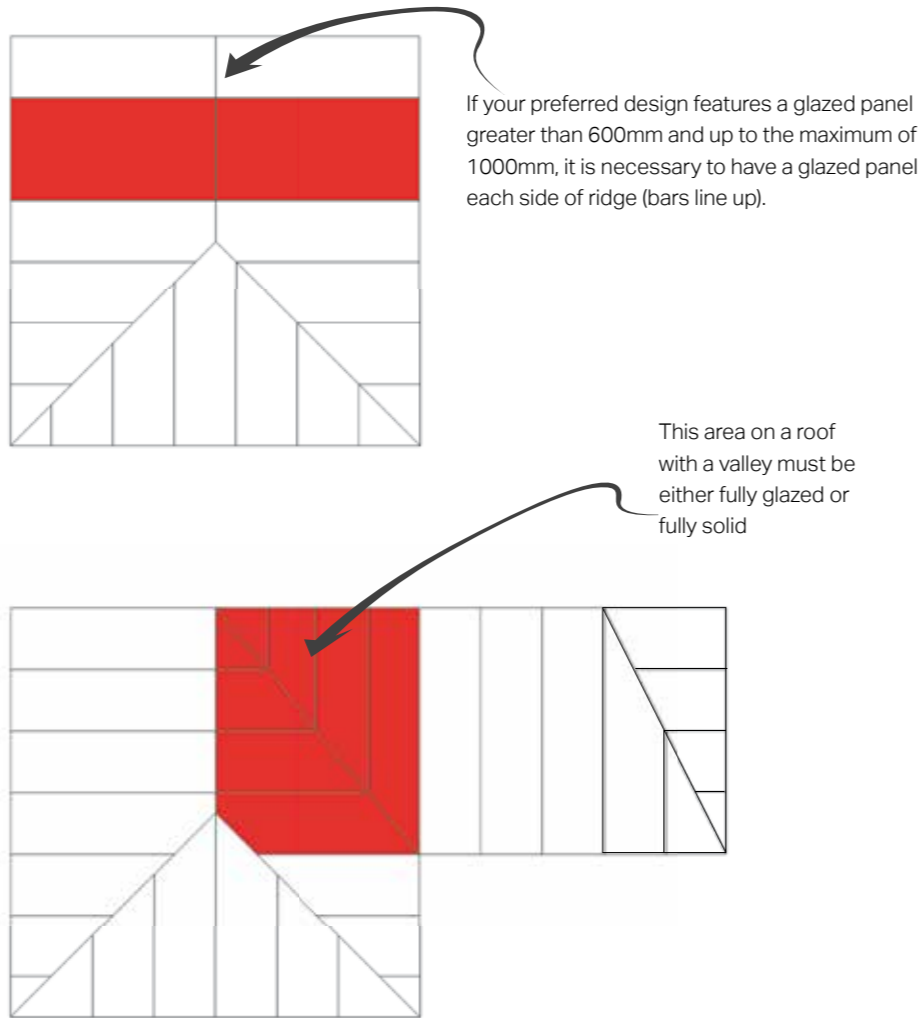

## Solid Panel Shapes max/min sizes

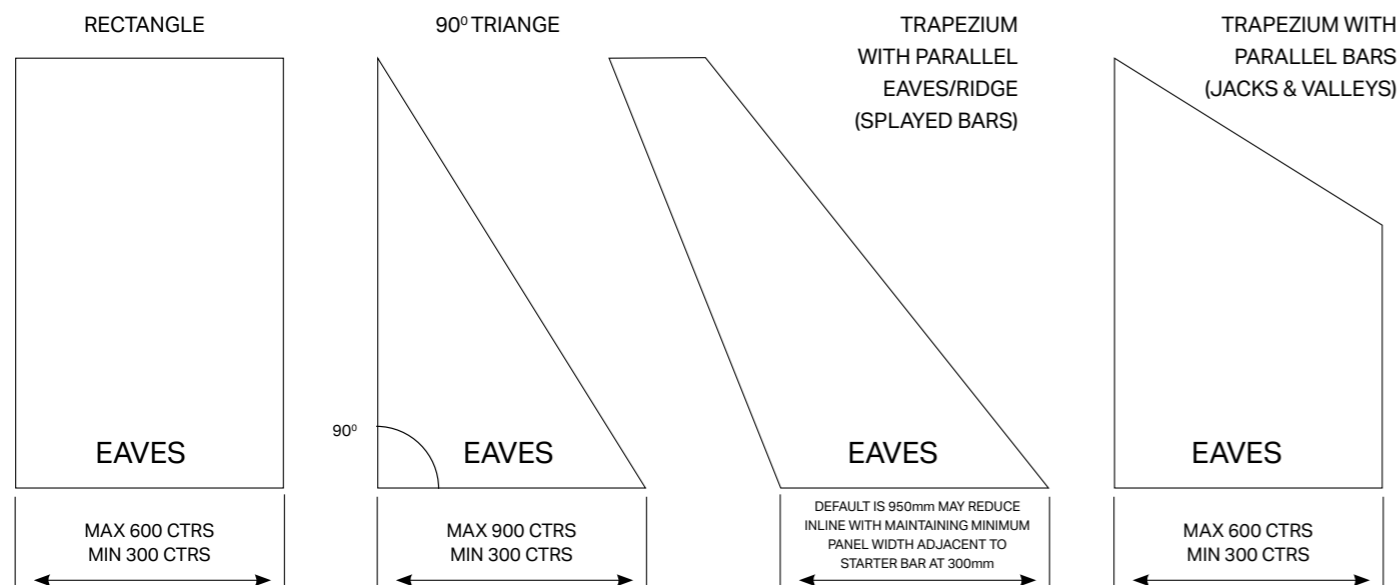

## ASSESSING THE EXISTING CONSERVATORY - STRUCTURAL SPECIFICATION GUIDELINES

**To upgrade an existing conservatory roof from polycarbonate or poorly performing glass to solid panels, it is necessary to undertake some structural checks that MAY lead to additional site works.**

### 1. PVCu Window Frames

- Unreinforced PVCu Frames. If at survey stage there is no reinforcement within the PVCu frames then the normal method of attaching the roof to the frames **MUST NOT** be used. The recommended method is the long standing Victorian fixing kit which uses a threaded rod and concealed nuts. Alternatively, if there is the option to screw up through the head of the frames, use a stainless steel screw, then behind the head of the screw should be a 20mm washer, so that the thread is biting into the aluminium of the eaves. Snip off excess thread to ensure screw doesn't foul gutter. Either option is suitable.
- Reinforced PVCu Frames. If at survey stage there is partial reinforcement (head of the frames as a minimum), then this helps with the connection of screws, particularly when screwing into the frame. For example when securing the roof to a window frame below with a screw going down through the eaves beam, the screw must go into steel reinforcement within the window frame.

Preferred method - all situations

If no reinforcing - screw up (avoiding penetration of the gutter)

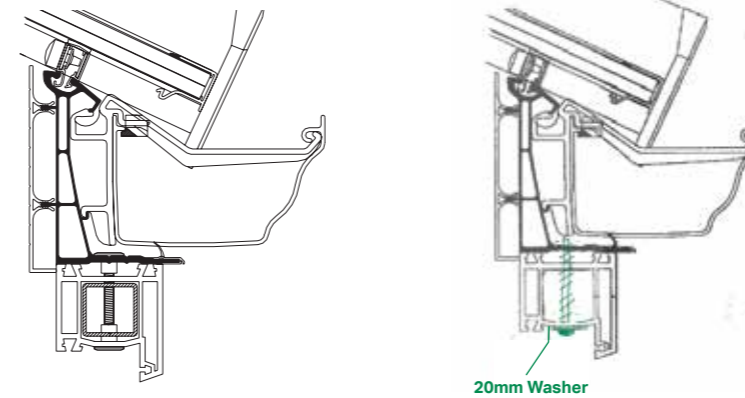

### 2a. Corner Posts

- Unreinforced PVCu Frames. If at survey stage there is no reinforcement within the PVCu frames it may be necessary to replace the corner posts. The dead load of Livinroof is 31Kg/m<sup>2</sup> plus the snow load which as a minimum is typically 60kg/m<sup>2</sup>. On a 5m x 5m roof for example, the load is 3414Kg which translates to a maximum loading at each corner of 8.37kN. Using the table below it can be seen that an aluminium corner post of 50mm square hollow section with a 2mm wall will be adequate - generally corner posts will be larger than this. At survey stage it may be difficult to confirm the presence of the aluminium inside the PVCu sleeve until the roof is removed. Assuming new frames are not being installed, it may be advisable to have spare corner posts available to swap with the existing.

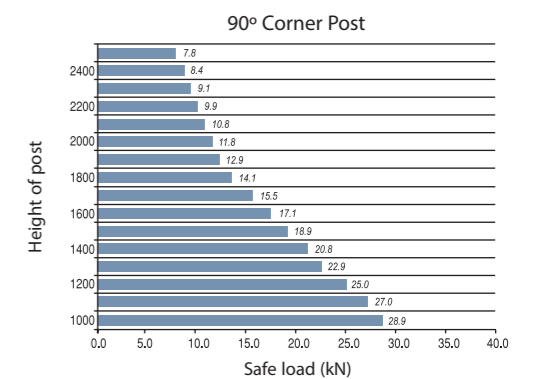
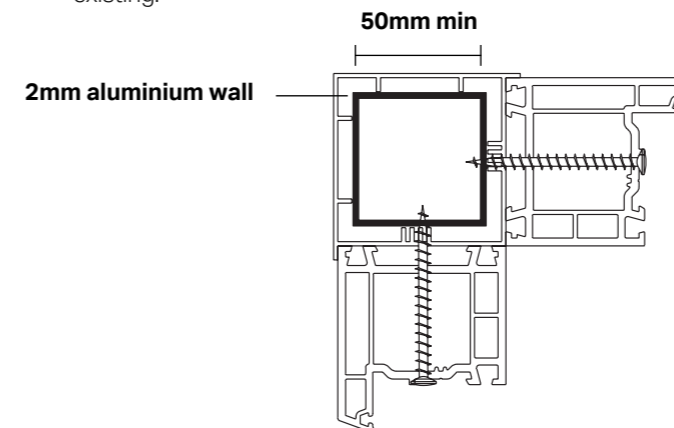



## ASSESSING THE EXISTING CONSERVATORY - STRUCTURAL SPECIFICATION GUIDELINES

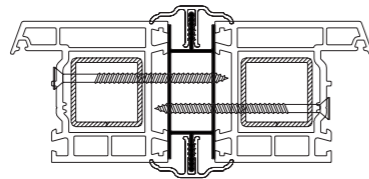

### 2b. Mullions

- An aluminium mullion performs a number of functions, namely:
  - acting as a wind post to prevent deflection of the frames by wind pressure
  - to support the roof's eaves beam
  - to assist with the connection of the side frames.
- Mullion as a wind post:- the size of the mullion depends on the height of the frame. With full height frames (2100mm) the mullion needs to be the full front to backdepth of the window frame and at least 20mm wide.
- Adding mullions to any existing frames is not viable – this option should be considered if the consumer has requested new frames/doors. Should the PVCu frames be replaced, the insertion of suitable mullions can obviate the need for reinforcement in the frames (as far as structural reasons are concerned) – when using mullions, always place a 20mm washer behind the head of the screw (similar instruction as to eaves beam).

Eaves beam charts based on eaves beam spanning between posts with tie bars aligned with posts / frame stiffener

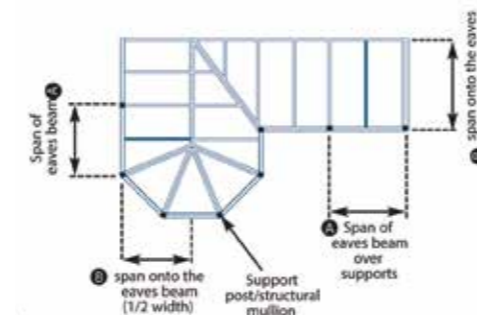
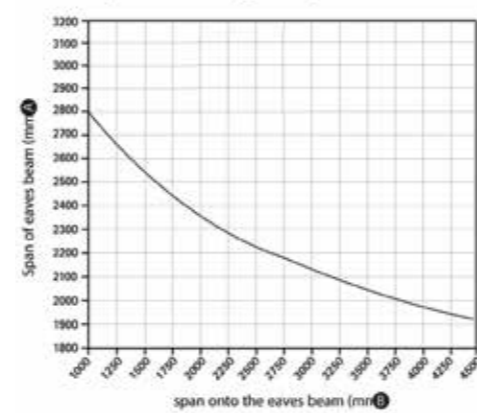

**WHERE FRAME DESIGN DOES NOT ALLOW RETRO FITMENT OF MULLIONS, ONE OPTION MAYBE TO UPGRADE FROM STANDARD EAVES BEAM TO SUPER DUTY EAVES BEAM - See p23 Appendix 4**

### 3. Foundations

- As everyone knows and appreciates, foundation design greatly depends on local ground conditions and advice should be sought from local LABC or an Approved Inspector like Jhai. However there are some rules which are absolute and therefore if the proposed conservatory falls outside this it will be necessary to underpin the existing or rip up the base and start again. Take up the old foundations if;
  - There is an inadequate depth of foundation. The strip foundation MUST be a minimum of 450mm and the concrete strip a minimum of 150mm thick.
  - There is visible movement between the house wall and the conservatory dwarf wall or cracks in the dwarf wall - this is a clear indication the foundations are not adequate and also require remedial work.
- Remediation work (mini piling etc.) can be undertaken cost effectively – QUICKBASE 0845 644 0000 if you wish to pursue this option.

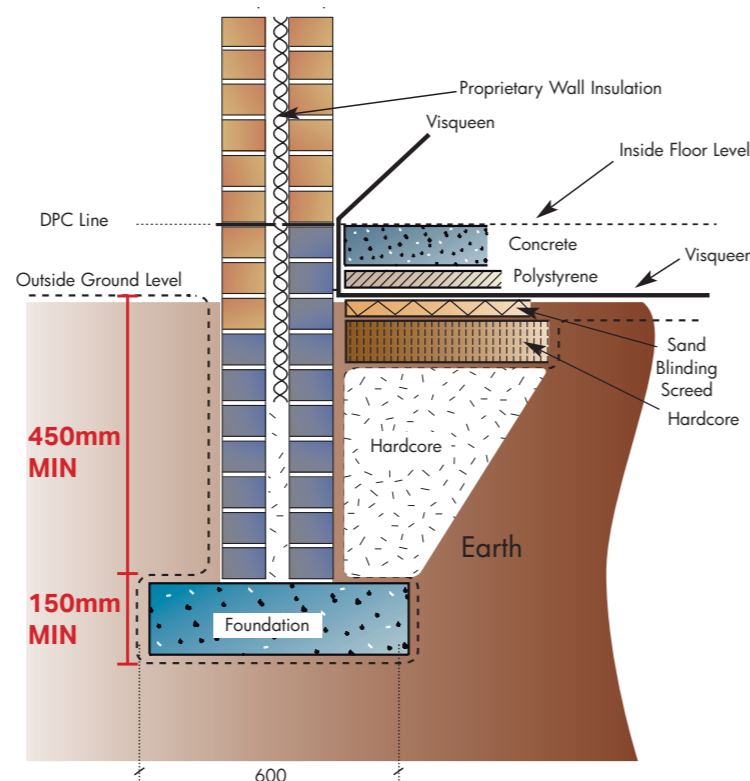

**IF IN DOUBT ABOUT STRUCTURAL COMPLIANCE, PLEASE CONSULT LABC, Jhai OR A STRUCTURAL ENGINEER**

## ASSESSING THE EXISTING CONSERVATORY - BOX GUTTERS

A key part of assessing the existing conservatory's suitability for upgrading is to assess any box gutter requirements, but in particular how they are adequately supported.

### Thermal Requirements

The roof its self is compliant with the Building Regulation's requirements and therefore if the thermally separating doors are being kept in place there will be no further considerations that need to be taken into account. Within Building Regulations there is an allowance for 25% of the floor area to have roof lights, windows or doors fitted. This is based on performance of 1.6W/Km<sup>2</sup> for windows and 1.8W/Km<sup>2</sup> for doors, therefore if better glass is used together with the better performance of the roof up to 30% glass is possible and still comply. U-Design provides guidance on this for precise calculations.

If the thermally separating doors are to be removed there are two main options.

1. Make the conservatory comply to building regulations on an elemental basis i.e .

Walls	0.28 W/Km <sup>2</sup>
Floor	0.22/Km <sup>2</sup>
Windows	1.6 W/Km <sup>2</sup> (up to 17%)
Doors	1.8 W/Km <sup>2</sup> (up to 13%)

2. Alternatively a SAP calculation is required on the whole house this approach allows offsets to be made i.e. new boiler or insulating the loft. SAP calculations need to be conducted by professional SAP assessors. Such as Wendlands Approved Inspector Jhai.

### Minimising Spread of flame.

In situations where the side wall is within 1m of the boundary there should be a firewall with a maximum opening for a window of 1m<sup>2</sup>. If this is not possible alternative measures will be required such as a solid brick built wall along the boundary or a solid timber lap fence would be adequate.

### Hip

Hip bars (without a tie bar at final point) are under compression (at the bottom they are pushing on the box gutter) when the box gutter is raised back the hip bar does not strike though the corner but sits on top of the plate. The plate is not strong enough to support this load, so the bolstered gallows bracket is used and the hip bar is fixed to the top of it with 4 x M6 bolts.

### Transom Tie Bar Support

Where a tie bar hits a raised back box gutter; the plate on the box gutter requires support. Transom bars connected by tie bars act as a truss and produce a concentrated point load at their location. Occasionally we can use two hanging brackets, but predominantly we use bolstered gallows brackets to support this load. Please note where the tie bar is more than a quarter way up the glazing bar; the tie bar bracket has to be fixed to the gallows bracket and not the glazing bar.

### Tie Beam & Tie Bar support

Is it not always possible to place a bolstered gallows bracket directly under the transom tie bar, due to window/door openings. Where this occurs two gallows brackets are placed either side of the opening and a beam is joined to the top of these brackets. This beam distributes the concentrated load (from the tie bar) to these gallows brackets. This design is sometimes used on box gutters that rise above 500mm, to provide support to the plate.

### Maintaining a Healthy Environment

Ensure there are opening windows so that the room can be ventilated now and then. Finishes are suitable for regular cleaning.



Custom designed gallows brackets are sometimes required

# LIVINROOF ORDER FORM

## ASSESSING THE EXISTING CONSERVATORY - BOX GUTTERS

The structural performance of the box gutter relies on the correct specification of fixings - please consult fixing suppliers for advice.

### Gallows Bracket

Requirements for gallows bracket –

- Roofs with tie bars require a gallows bracket at each tie bar position.
- Roofs over 3.0m width or projection require a gallows bracket at every fourth glazing bar (ie typically 2.4m centres).
- Maximum span for unsupported box gutters (no fixings into house wall).



### Alternative Support

- Unless the strength of the masonry to which the gutter is attached is known, Wendland generally recommends the use of brick piers to support the box gutter, suitably tied to the host wall using a proprietary fixing rail/tie irons. A minimum expected size is 225 x 225mm.
- With timber soffits and fascias, Wendland generally recommends the use of brick piers to support the box gutter.



### Further Requirements

- Straps required for all box gutters.
- Straps to be positioned within 75mm of glazing bar centres (centre of strap to centre of bar).



Hanger Bracket - alternative support for 165mm box gutters.

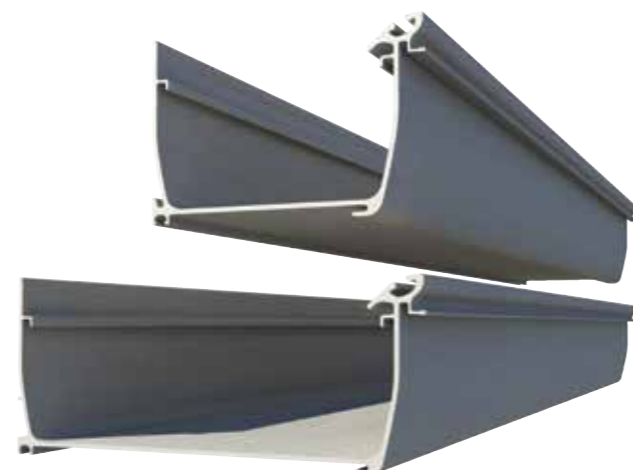

Top: 165mm Standard box gutter.  
Above: 265mm Standard box gutter.

- ORDER** e: rooforder@wendland.uk.com
- QUOTE** e: rooforder@wendland.uk.com
- New Build     Replacement Project

**PLAN VIEW**

ACCOUNT No.

Company Name .....

Order Number .....

**JOB REFERENCE** .....

Company Contact .....

Telephone No. ....

Email .....

Delivery Address .....

.....

.....

**POSTCODE** .....

Delivery Date Req .....

Quotation Ref .....

**CRITICAL INFORMATION**

**\*Required for structural snow / wind loading**

\*Site Postcode .....

Roof Pitch (°) .....

Roof height restriction .....

Frame width .....

**FRONT ELEVATION**

**CUSTOMER NOTE: Please carefully read the Livinroof installation guide before filling in order details.**

### HOW TO PLACE AN ORDER FOR LIVINROOF:

1. Sketch plan & elevations.  
(If necessary, attach photos of existing property. Indicate on drawings if any part of project is existing).
2. Mark and caption the positions of all walls, brick piers, windows/doors, cut outs / intrusions.
3. Mark the preferred positions of any  
a) roof windows  
or b) rectangular glazed panels.
4. Upon placement of your Livinroof order, an order confirmation is generated which must be signed and emailed back.

**LEFT ELEVATION**

**RIGHT ELEVATION**

Please sign and return to  
rooforders@wendland.uk.com

SIGNED .....

DATE .....



# LIVINROOF ORDER FORM



JOB REFERENCE .....

## ROOF INFORMATION

- On Fascia     Below Fascia\*     Full Height Walls     Partial Walls     Full Height Frames

If fitting to a bungalow please indicate Soffit Depth .....

\*N.B. **Bleow fascia** is always on boxgutters, 30mm frame add on is needed but not supplied.

## EAVES BEAM

- Standard (VAAAH)  
 Structural (SEB)  
 Gable beam  
 (MUST be used with Cornice)

## EXTERNAL PELMET

- U-Tec through colour composite (to match 7016)     Aluminium powder coated sandwich (to match 7016)

## INTERNAL PELMET

- Specify with this order     Upgrade with retro fit     Standard Width (300-600mm)     Other (600-1200mm)

Original roof job no. if applicable: .....

Please state (mm): .....

## CORNICE

- Style     Curved     On Cill

- Colour     White     Urban Grey     Deepas White     Landmark Green     Pure Cream     RAL/BS Colour .....
- RAL 9003,    RAL 7016,    INTERPON SC050E,    BS14C35,    RAL 1015,  
 GLOSS 80%    GLOSS 30%    GLOSS 80%    GLOSS 80%    GLOSS 30%     Gloss % .....

## CONSERVAGLASS OPTIONS - BLACK WARM EDGE SPACER

### TIER 1 - CONSERVAGLASS

- C'Glass SMG Blue     C'Glass SMG Neutral  
 C'Glass SMG Bronze     C'Glass SMG Aqua

### TIER 2

- C'Glass 4S Blue     C'Glass 4S Neutral  
 C'Glass 4S Bronze     C'Glass 4S Aqua

### TIER 3

- C'Glass SMG  
 Ultimate Blue

### TIER 4

- C'Glass SMG  
 Ultra83 Blue

## ROTABOND SEALANT - MS POLYMER

- White (NCGS001W)     Black (NCGS001B)

No. Tubes Req: .....  
 N.B. For use with Conservaglass

## CONSERVAFLASH

- Soaker Only  
 Yes

## ROOF VENTS AND MECHANISM (mark plan)

- Manual with brass     Manual with chrome     Electric switch/mechanism     Electric with rain sensor / thermostat

## ANCILLARY EXTRAS

### IMPORTANT NOTE 1

The installer is responsible for ensuring that where Livinroof is supported by means such as timber frame walls, the structure provides enough lateral support and resistance to wind uplift. Further guidance can be obtained through our system overview. Wendland cannot be responsible for the structural adequacy of any existing building work used as part of an overall conversion. While assistance is provided, ultimate responsibility to secure Building Regulations / approvals lies with the retail installer.

### IMPORTANT NOTE 2

U-Design is the final arbiter on price and specification decisions.

### IMPORTANT NOTE 3

The Livinroof components have been designed and manufactured to meet the specification of each individual job. Any significant on site modifications particularly relating to the repositioning of any structural members will invalidate the product's warranty and compromise the structures integrity. If adjustments are required due to site conditions please consult Wendland. Tie Bars / Tie Beams will be specified by Wendland and will appear on your confirmation. Always check the confirmation carefully.

Job No.:3598

Please sign and return to

rooforders@wendland.uk.com

SIGNED .....

DATE .....

p2 of 2

## APPENDIX 1 - RESIN ANCHORS

### The correct selection/specification of fixings for Livinroof is CRITICAL.

Wendland recommends HILTI chemical anchors where specified and expanding anchors in other locations (to resist pull out forces). Using HILTI product codes/descriptions, use a HIT-V 80mm x M8 threaded anchor (stud\*) fastened into a 10mm clean drill hole with gun injected mortar or adhesive capsules (with a minimum 80mm embedded) - always rigorously follow manufacturers guidance www.hilti.com

In addition Wendland recommends the following alternatives;

Fischer M8/M10 masonry injection anchor FIS V

Rawl Fixings M8/M10 CFS RM50 or CFS RP30

\* Design load for each stud 2.5kN

## APPENDIX 2 - CAVITY TRAY ASSESSMENT

### It is good practice to undertake a risk assessment to determine IF cavity trays should be retro fitted.

In zones 1 and 2, cavity tray installation is based upon risk assessment - factors include determining if elevation faces prevailing wind, absorbandy of brickwork and monitor joint type. Cavity trays **MUST** be installed in severe/very severe exposure zones (3 and 4).

KEY	EXPOSURE ZONES	Approximate wind-driven rain* (litres/m <sup>2</sup> per spell)
	1 Sheltered	Less than 33
	2 Moderate	33 to less than 58.5
	3 Severe	58.5 to less than 100
	4 Very Severe	100 or more

\* Maximum wall spell index derived from BS8104



## APPENDIX 3 - TIE BARS

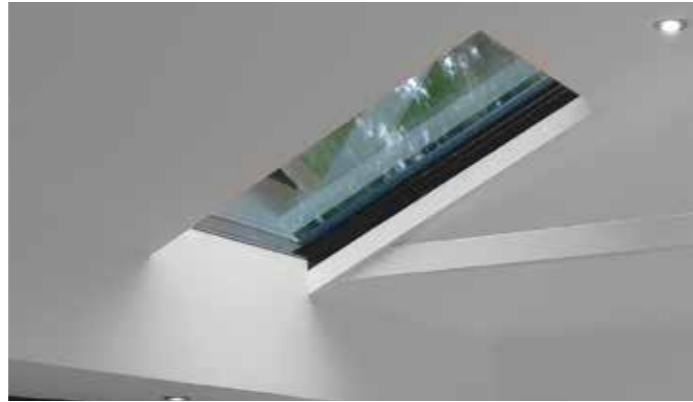
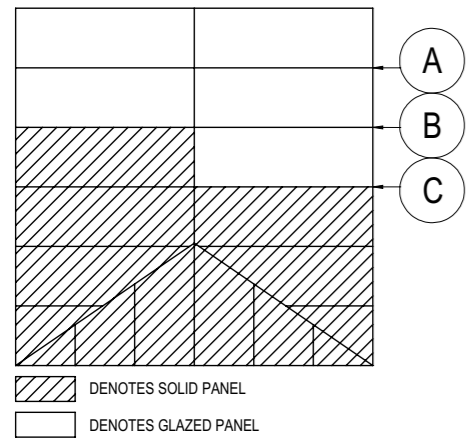

Tie beam

Glass - glass  
Traditional tie bar

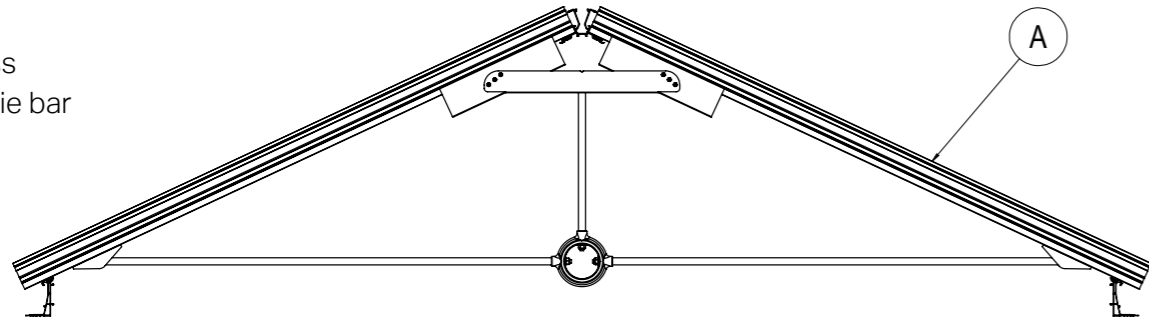

Solid - glass  
Traditional tie bar

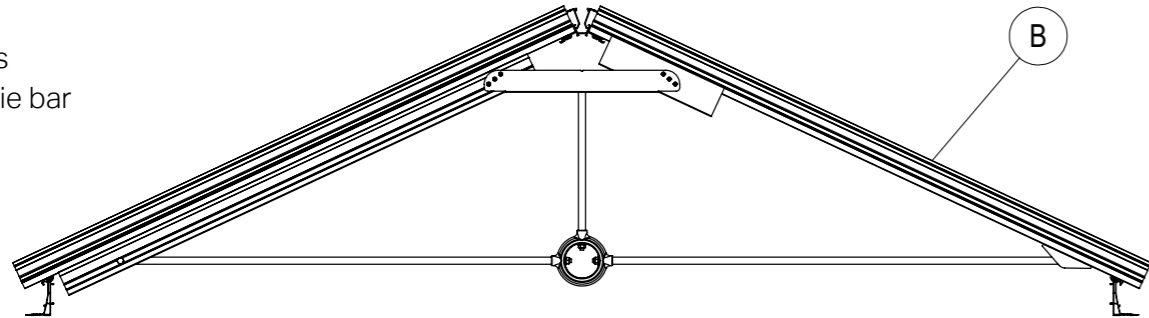

Solid - solid  
Traditional tie bar

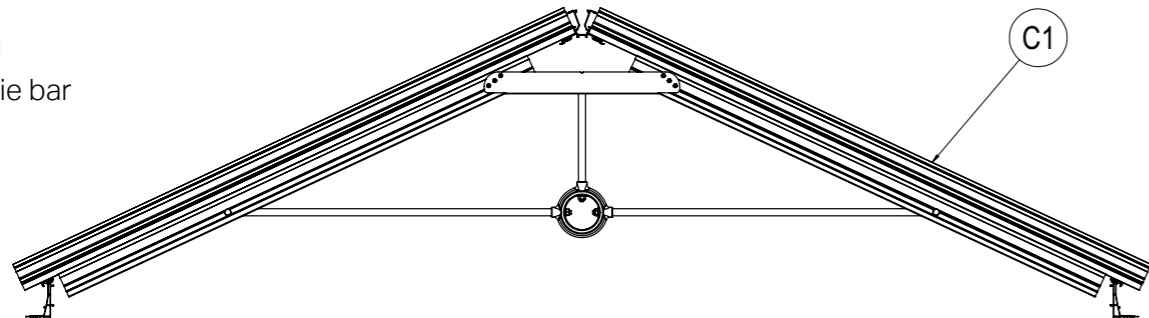

Solid - solid (Standard Option)  
tie beam

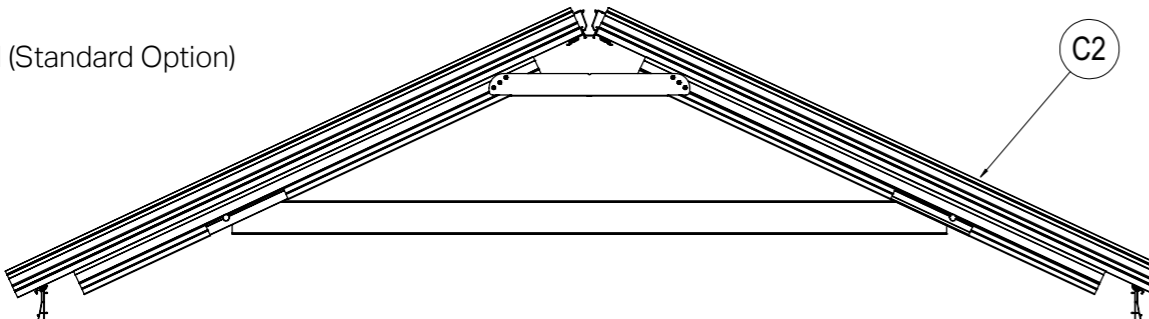

## APPENDIX 4 - SUPER DUTY EAVES BEAM

In some situations where mullions cannot be added to an existing frame arrangement, then an upgrade to the Super Duty Eaves Beam can provide the additional load distribution required.

### Technical Specification

**IMPORTANT NOTE FOR FITTERS**  
Super Duty Eaves Beam sits 38mm higher and eaves beam is further 25mm 'in board' of the frames

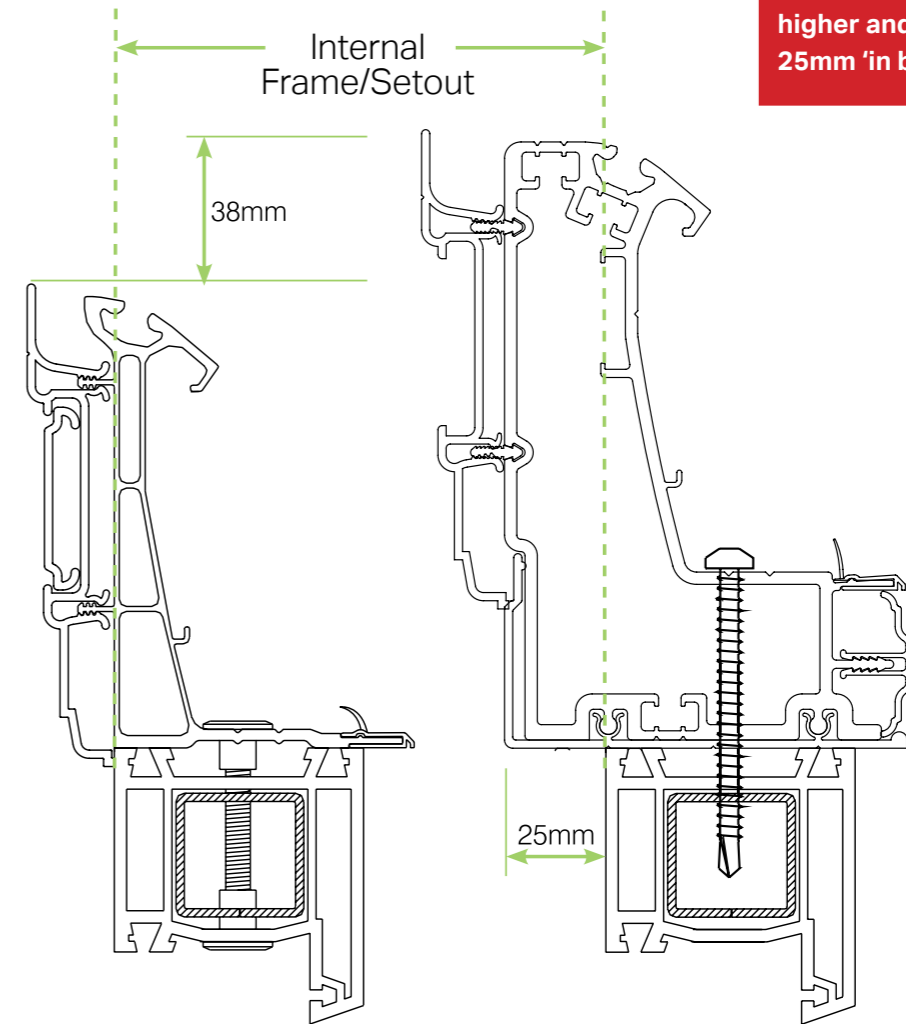

Standard Eaves Beam

with recommended means of installations VIC fixing kit.

Super Duty Eaves Beam

VIC fixing kit not suitable for this application.

- Structural 'beefier' aluminium profile that uses existing PVCu components to clad and cap for optimum performance.
- Sits 38mm taller than the standard eaves beam (remember this when calculating overall ridge heights). Be aware - where height is critical, such as when windows above may foul or overhanging bungalow fascias.
- It is specified all the way round the nominated conservatory.
- Readily interfaces with box gutters and Gable Support Beam, to offer maximum integration and configurability.



# APPENDIX 4 - SUPER DUTY EAVES BEAM

## Structural Span Performance

### 1. Opening span performance

Doors into the front elevation of a Lean to or a side elevation of a Victorian/Georgian/Gable style conservatory

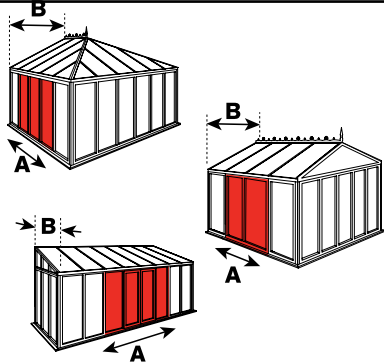

Super Duty Eaves Beam

Eaves Span Chart - Standard Load - Glass (4/../4) - Snow 0.6kN/m<sup>2</sup>

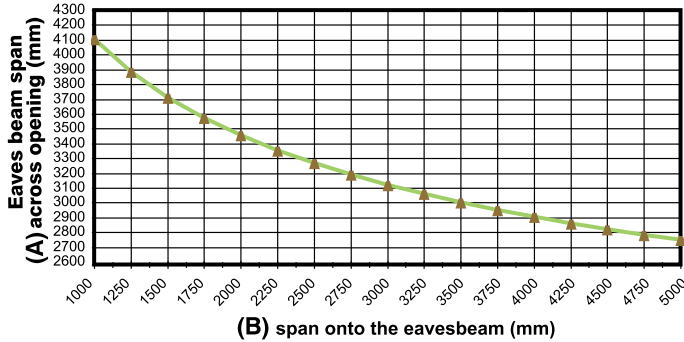

### 2. Opening span performance

Doors into the front elevation of a Georgian style conservatory with hip bars

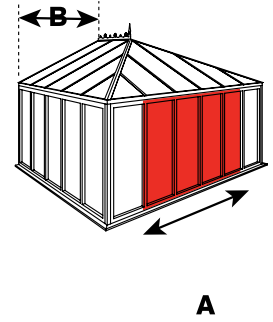

Super Duty Eaves Beam

Eaves Span Chart - Triangular Load - Glass (4/../4) - Snow 0.6kN/m<sup>2</sup>

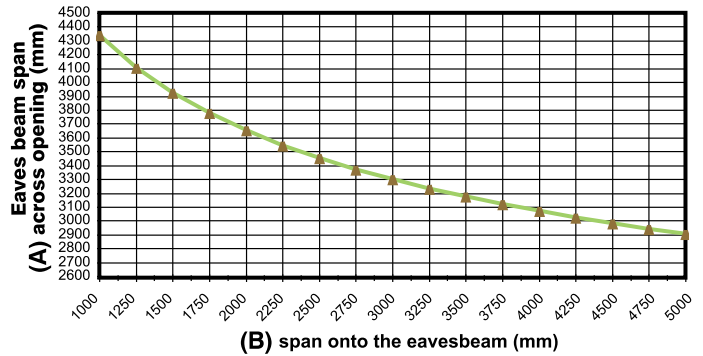

### 3. Opening span performance

Doors into the front elevation of a Gable style conservatory

This style uses the established Gable Support Beam for doors in the front and standard eaves beam on the sides. For doors in the sides, use Super Duty Eaves Beam on the sides and preferably, Gable Support Beam on the front - cost accordingly

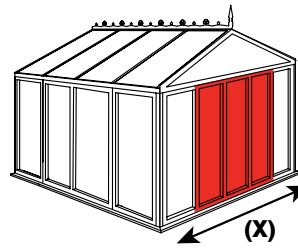
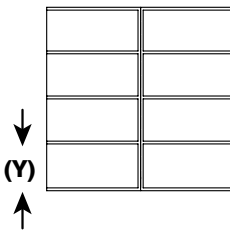

#### Example -

For a Gable conservatory with a width of 4000mm (X), a roof pitch of 25° and with 750mm distance to the first glazing bar (Y), the maximum opening span for the doors would be 2900mm.

Available unsupported span of Gable Eaves Beam (0.6kN/m<sup>2</sup> snowload and 4/../4mm glass units)

PITCH	FIRST BAR CENTRE (Y)	WIDTH OF GABLE (mm) (X)																	
		1000	1250	1500	1750	2000	2250	2500	2750	3000	3250	3500	3750	4000	4250	4500	4750	5000	
15°	1000									2900	2800	2750	2700	2650	2600	2550	2500	2450	
15°	750										3100	3050	2950	2900	2850	2800	2750	2700	
15°	600											3250	3200	3100	3050	3000	2950	2900	
20°	1000									2900	2800	2750	2700	2650	2600	2550	2500	2450	
20°	750										3100	3000	2950	2900	2850	2800	2750	2700	
20°	600											3250	3200	3100	3050	3000	2950	2900	
25°	1000									2900	2800	2750	2700	2600	2550	2500	2450	2400	
25°	750										3100	3000	2950	2900	2800	2750	2700	2700	
25°	600											3250	3150	3100	3050	3000	2950	2900	
30°	1000									2850	2800	2750	2650	2600	2550	2500	2450	2400	
35°	1000									2850	2800	2700	2650	2600	2550	2500	2450	2400	
40°	1000									2850	2750	2700	2650	2550	2500	2500	2450	2400	

All configurations in the shaded area have an opening span the full width of the conservatory